

Secure UHF Tags with Strong Cryptography

Development of ISO/IEC 18000-63 Compatible Secure RFID Tags and Presentation of First Results

Walter Hinz, Klaus Finkenzeller and Martin Seysen
Giesecke & Devrient GmbH, Prinzregentenstrasse 159, 81677 Munich, Germany
{Walter.Hinz, Klaus.Finkenzeller, Martin.Seysen}@gi-de.com

Keywords: UHF Tag, Public Key Cryptosystem, Rabin, Montgomery

Abstract: This paper presents a concept for an UHF tag supporting cryptographically strong authentication which is based on the Rabin-Montgomery public key cryptosystem in accordance with the framework of ISO/IEC 29167-1. It uses an easily computable long integer square operation for the public key encryption of a tag ID record. Only a legitimate interrogator who is in possession of the private key can decrypt this message and retrieve the authentic tag ID. A working prototype based on a standard FPGA is shown which demonstrates the feasibility of the proposed cryptographic function.

1 INTRODUCTION

Backscatter-coupled RFID systems are being used in a large number of applications such as logistics, supply chain, warehouse management, retail stores, and similar applications.

Backscatter-coupled RFID systems are mainly operated in the UHF frequency ranges 868 MHz (Europe) and 915 MHz (USA, Asia). These UHF-RFID Systems are primarily covered by the standard (ISO/IEC 18000-6, 2010).

The majority of the applications mentioned above operate according to ISO/IEC 18000-6 Type_C (ISO/IEC 18000-6C will be published as Part -63 in the future (ISO/IEC FDIS 18000-63)) which describes the physical characteristics and protocol behaviour of the so called "Electronic Product Code", the EPC. This standard is designed for the fast detection of huge numbers of transponders in the field at the same time, and for a small amount of data to be transferred between an interrogator and a tag.

A typical transponder is field-powered and uses modulated backscatter signals to transmit data back to the interrogator. The operating range of these passive (or field-powered) transponders is mainly limited by the ability to get sufficient power from the field into the transponder in order to operate the silicon chip. Typical maximum operating distances of such passive transponders are between 3 and 10 m.

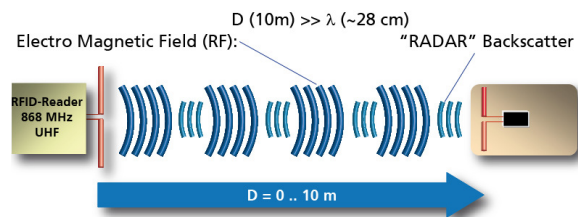

Figure 1: Principle of UHF RFID.

Another class of transponder uses an on-board battery to supply the silicon chip with energy. The operating range of these battery assisted passive (BAP) tags is mainly limited by the interrogator's ability to receive and detect the modulated backscatter signal from the transponder, in addition to its own high-power signal. Typical maximum operating distances of BAP transponders are up to 25 m.

Despite of these range limitations, there are real time locating systems (RTLS), which are able to detect a locally powered transponder from a distance of 100 m and above. These systems are much more sensitive than RFID readers, because they do not suffer from the strong signal carrier emitted at the same antenna, as an interrogator does.

With special equipment like communication receivers and high gain directional antennas, there is always the possibility to eavesdrop a communication between an UHF-RFID interrogator and a transponder from a considerable distance up to several hundreds of meters.

In many cases it is not desirable that an object or subject carrying an RFID tag can be identified or tracked, either with a standard RFID interrogator or by eavesdropping the communication between the tag and an interrogator. For example, whenever the tag is associated with a person, privacy rules apply. Furthermore, it could be possible to transmit strong backscatter signals with forged information which superimpose the original data sent by the tag.

Therefore, it is desirable to have a secure variant of RFID, where cryptographic functions allow only a legitimate interrogator to identify a tag, to impede eavesdropping and to prevent the infiltration of false information.

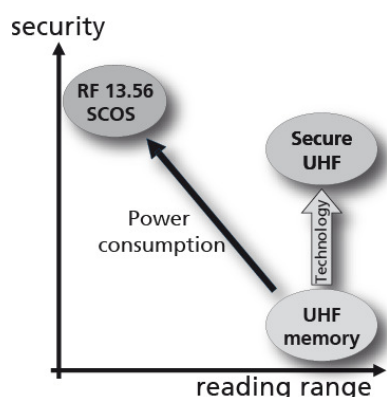

Figure 2: Technology leap with Secure UHF.

For inductively coupled RFID devices, mainly operated in the 13.56 MHz RF frequency range, cryptographic functions and even complex smart card operating systems (SCOS) are available for nearly one and a half decades now. Inductively coupled RFID devices however are operated close to the reader, typically at a distance of up to 10 cm. Due to the strong coupling between the reader and the tag's antenna inductive RFID systems have sufficient power to operate complex microprocessors even with cryptographic co-processors. UHF RFID tags on the other hand have to be operated with about 10 to 100 times less power. Therefore, UHF RFID tags in the past provided no cryptographic security at all (Finkenzeller, 2012).

Over the years however, silicon technology continuously improved, resulting in ever-decreasing power consumption. In the recent years a point has been reached, where cryptographic functions on UHF RFID tags seem to become feasible. For that reason, ISO/IEC JTC1/SC31 has recently started standardisation activities to provide crypto suites for future UHF RFID tags. The results will be published in a new standard series ISO/IEC 29167 with differ-

ent parts, which are currently available in first working drafts (WD).

In the remainder of this paper a concept for a secure UHF tag with strong cryptography will be presented in section 2. As the required protocol extension is not yet available, a first prototype working with currently defined standards, and first results are shown in sections 3 and 4.

It is paramount that the secure RFID tag shall be fully compatible with ISO/IEC 18000-6, such that interrogators conforming to this standard can be continued to be used. The proposed protocol is designed along the command structure which is currently being discussed in the context of *security suites* in ISO/IEC WD 29167.

Especially because suitable interrogators are not yet available, a preliminary workaround protocol had to be used to achieve first results.

2 PROTOCOL CONCEPT FOR A SECURE RFID TAG

2.1 General Concept

In accordance with WD 29167-1 we developed a secure protocol for authentication and identification of a tag by use of the *Authenticate* command as defined in the working draft. Within this framework we defined a specific format for the *payload* field. In the following the content of this payload is explained.

The authentication protocol comprises the encryption of a message by the tag containing the tag's identification information. In order to guarantee the freshness of the encrypted message, random numbers originating both from the interrogator and the tag are also included. Because the confidentiality of a key stored in the tag cannot be assured, it is necessary to employ a public key cryptosystem with the public key stored in the tag(s) and the private key on the interrogator side.

In the following, the particular cryptosystem and the format of the plaintext message is explained. In the context of public key cryptosystems the message is considered as a long integer number M , which constitutes the payload field as defined in WD 29167-1.

2.2 The Rabin Cryptosystem

For the authentication part we used the Rabin public key cryptosystem which is based on the modular multiplication of long integers (Rabin, 1979). A step by step explanation of the algorithm can be found in (Menezes et al., 1997).

A proof that breaking a particular encryption scheme is as difficult as solving a computational problem which is believed to be difficult, is a desirable property. The *Rabin* public key encryption scheme was the first example of provable security, because the problem of breaking it is computationally equivalent to factoring.

In order to generate a public key and the corresponding private key, two random and distinct primes p and q of roughly the same size need to be generated. To keep the decryption algorithm simple, we assume that these primes satisfy the congruence condition

$$p \equiv q \equiv 3 \pmod{4} \quad (1)$$

Here p and q together constitute the private key while the product

$$n = p \cdot q \quad (2)$$

is the public key.

The plaintexts in the *Rabin* encryption scheme are the integers $0 < M < n$. The ciphertext C corresponding to M is defined as the square of the long number M modulo n

$$C = M^2 \pmod{n} \quad (3)$$

Rabin decryption thus means taking the modular square root of cipher text C ,

$$M = \sqrt{C} \pmod{n} \quad (4)$$

In the general case there is no efficient algorithm to find M . For a modulus $n = pq$, with p and q prime, the following roots can be determined:

$$m_p = \sqrt{C} \pmod{p} \quad (5)$$

$$m_q = \sqrt{C} \pmod{q} \quad (6)$$

By virtue of the congruence condition (1) the two roots are given by

$$m_p = \pm C^{\frac{p+1}{4}} \pmod{p} \quad (7)$$

$$m_q = \pm C^{\frac{q+1}{4}} \pmod{q} \quad (8)$$

By means of the *extended Euclidian algorithm* it is possible to determine integers y_p and y_q which satisfy the equation

$$y_p \cdot p + y_q \cdot q = 1 \quad (9)$$

Finally four roots of C , namely $+r$, $-r$, $+s$, and $-s$, can be calculated by application of the *Chinese Remainder Theorem* as

$$+r = (y_p \cdot p \cdot m_q + y_q \cdot q \cdot m_p) \pmod{n} \quad (10)$$

$$-r = n - r \quad (11)$$

$$+s = (y_p \cdot p \cdot m_q - y_q \cdot q \cdot m_p) \pmod{n} \quad (12)$$

$$-s = n - s \quad (13)$$

Which one of the four roots ($\pm r$, $\pm s$) is the desired clear text message M has to be determined by searching for a specific characteristic, such as an embedded checksum or other redundant information.

2.3 Montgomery Multiplication

Modular reduction as in equation (3) is usually quite cumbersome to calculate for a microprocessor with low capabilities, because of the division involved. The paper (Montgomery, 1985) proposes an alternative computation scheme which requires only multiplication. The cost of multiplication is much less than that of division, especially if a hardware multiplier is available.

Consider a *residue* R where R is a power of 2 and an odd modulus $n < 2^k \leq R$. In other words, R a power of 2 which is larger than n . Usually k is a multiple of the word size w of the processor performing the hardware multiplication. For a suitable R one calculates

$$C^* = M^2 R^{-1} \pmod{n} \quad (14)$$

Without the cost for squaring M , the quantity C^* can be computed with $(k/w)^2 + O(k/w)$ multiplications of w -bit numbers, and without any divisions, see (Montgomery, 1985) for details. Squaring M costs $0.5(k/w)^2 + O(k/w)$ more multiplications, so that in total we need $1.5(k/w)^2 + O(k/w)$ multiplications of w -bit numbers.

One should be aware that $C^* \neq C$, and before we can proceed with calculating the roots, we have to undo the effect of the Montgomery multiplication

$$C = C^* R \pmod{n} = (M^2 R^{-1}) R \pmod{n} \quad (15)$$

The final calculation needs, apart from approximately the double length operands, just one conventional modular reduction, but this is made on the host system connected to the interrogator where computing power and space requirements should not pose any problem.

If the modulus n is chosen to satisfy the condition

$$n = 1 \pmod{2^{k/2}} \quad (16)$$

which means that about one half of the least significant bits of n (except for the last one) are zeroes,

128 bytes = 10 bytes 10 bytes n bytes x bytes 2 bytes 1 byte						
Corresponds to the length of modulus	80 bits reader random challenge	80 bits tag random number	TLV-coded signed Tag ID	Variable length filling	Checksum	The last byte must be left free; set to zero

Figure 3: Identification message (before MIX).

about one third of the necessary multiplications to evaluate equation (14) can be saved.

Unlike modular reduction the Montgomery multiplication method does not guarantee that the result in equation (14) is actually smaller than the modulus n , therefore a final reduction step may be necessary which causes high computational load and leaks side channel information due to different timing with and without reduction. The probability for a modulus overflow in equation (14) can be significantly reduced by choosing the residual exponent k a bit larger than actually required. In practical terms one selects the exponent as $k \approx \log_2 n + d$ where d is a security parameter, so that k is a multiple of the tag microprocessor hardware multiplier's word length.

In our example we chose $n = 1024$ and $d = 64$ for a 16×16 multiplier unit, giving $k = 1088$ and $R = 2^k$.

2.4 The Identification Message

The most important part of the identification message is the unique tag ID. In order to preserve its authenticity it is digitally signed before it is personalised into the tag during production. The signature method is out of scope for these considerations; however, for practical purposes one would choose an appropriate Elliptic Curve Cryptosystem (ECC), because the size has to fit into the tag authentication message.

With the parameters chosen, the authentication message has a size of 128 bytes. To resolve the ambiguity of the four possible square roots two bytes are reserved for a checksum and the most significant byte must contain 0x00. Only the root with the correct checksum will be processed by the interrogator. This leaves 125 bytes for the actual ID content.

As discussed earlier we need some random bytes to guarantee the freshness of the encrypted ID message and to prevent the recycling of an eavesdropped ID record. We chose 10 random bytes to be contributed by the interrogator and another 10 bytes contributed by the tag.

After these considerations 105 bytes remain for the ID information. To gain flexibility in the size of the individual elements of the signed tag ID these are TLV (tag-length-value) encoded. If the ID in-

formation does not fill the whole space available, the tag will insert the necessary amount of fresh random data in order to provide the required total of 128 bytes.

Figure 3 shows the composition of the identification message described so far. If we used this ID message for encryption there would be some risk of leaking information, because to a large extent (the n bytes signed tag ID) these data are static. The introduction of a MIX function neutralises this problem, because it interleaves static and dynamic components.

The following C-like pseudo code describes the operation of the MIX function:

```
for (i=0; ; ++i) {
  get 5 bytes from signed ID; if out
    of data, get random bytes;
  if (i == 10) break;
  get 1 byte from reader challenge;
  get 5 bytes from signed ID; if out
    of data, get random bytes;
  get 1 byte random as tag challenge;
}
append checksum;
append 0x00;
```

2.5 Overall Message Flow

The overall message flow for a secure tag authentication is as follows:

First the interrogator generates a 10 byte random challenge and sends it to the tag.

Then the tag processes the identification record as described above, mixing the interrogator challenge into the message and encrypting it according to the Ramon-Montgomery scheme. The result is backscattered to the tag.

The interrogator has to decrypt the message and find the correct root out of the four presented by the algorithm. Then it has to roll back the effects of the MIX function and check whether the returned interrogator challenge is identical to the one sent. This approves that the tag is in possession of the public key.

Afterwards the interrogator investigates the signed ID record. If the signature can be verified with the public ECC key, the tag is identified and authenticated. The tag challenge can be preserved

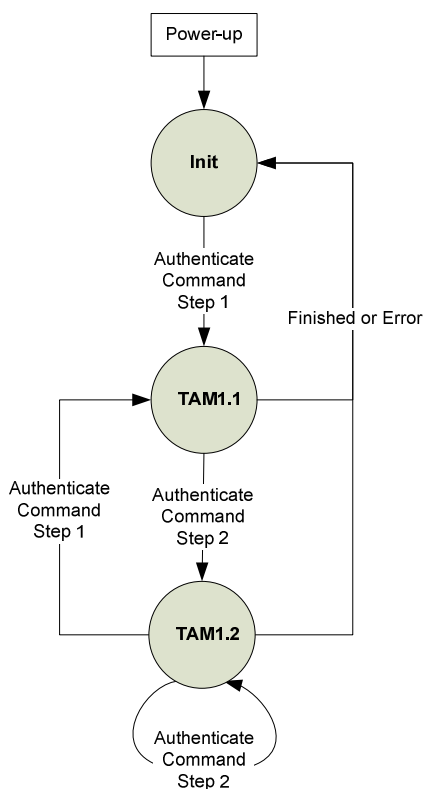

Figure 4: Tag state diagram.

for further processing, as it can authenticate the interrogator to the tag.

2.5.1 Tag State Diagram

The logical process flow as developed above is now embedded into the framework as defined in WD 29167-1. In accordance with the working draft the tag can assume the states as depicted in figure 4.

A sequence of *Authenticate* commands needs to be sent to the tag to complete a full tag authentication protocol. For a successful authentication the entire sequence needs to be executed successfully. The crypto suite state transitions triggered by the authentication payloads are summarized in the next subsection below. State transitions and tag responses are according to the payloads of the *Authenticate* command sent by the interrogator.

The processing of the *Authenticate* command may include generation of an authentication cryptogram that will be returned in the tag's response; the tag may also return some buffered data. Because the authentication protocol produces the output data consecutively in the correct order, it is advantageous

to split the response in small pieces and to return these pieces in parallel to the ongoing calculation.

After power-up the tag transitions to the 'Init' state. Once the tag receives an *Authenticate* command with payload for step 1, it processes the command, sends the response and transitions to TAM1.1 expecting an *Authenticate* command with payload for step 2. When the tag receives the first *Authenticate* command for step 2, it processes the command, sends the response and remains in TAM1.2 as long as there are authentication data bytes remaining to be sent. In TAM1.2 the interrogator sends as many *Authenticate* commands as required to fetch the entire authentication data produced by the tag.

The interrogator indicates the length of the authentication cryptogram in the payload of the *Authenticate* command for step 1. The tag indicates the number of bytes still available to fetch in the payload of the response message.

Whenever the tag receives an *Authenticate* command with payload for step 1, it resets all variables, transitions to TAM1.1 and starts processing the command. The tag transitions to Init state once it has sent out the last fragment of authentication cryptogram.

In case of failure during one of the steps of the protocol, the crypto suite transitions to the 'Init' state.

When Rabin-Montgomery encryption and I/O are overlapping in the tag there can be a couple of short response packets from the tag, the exact behaviour being dependent on tag firmware optimization. In any case, the final packet carries a success status word in its payload or an error indicator, if applicable.

2.5.2 Tag Authentication

The sequence of exchanged messages for tag authentication is depicted in figure 5. The first message includes a random challenge generated by the interrogator and sent to the tag. The tag response is an encrypted message that only the legitimate interrogator can decrypt, since it possesses the necessary private key.

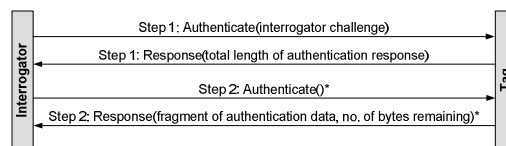

* The message is sent multiple times to retrieve all the remaining bytes.

Figure 5: Message exchange for tag authentication.

tire authentication record it is able to authenticate the tag.

If the tag receives a message that is not formatted as described in the following section it shall respond with an error code and transition to 'Init' state.

2.5.3 Authentication Command

The authentication is performed in two distinct steps. In step 1 of the *Authenticate* command the interrogator sends a 10 byte random challenge to the tag as indicated in the specification of the cipher.

As the tag cannot process the authentication within the response timeout, it answers with a message indicating the expected size of the Ramon-Montgomery encrypted cipher test. The tag assumes state TAM1.1 and begins the calculation of the cipher.

In order to fetch the result, the interrogator issues step 2 of the *Authenticate* command after some time. The tag assumes state TAM1.2 and responds with the first fragment of the resulting message, together with an indication of the number of bytes missing. The size of the fragment returned is determined by the progress of message calculation and the maximum which can be transferred in a single message.

If there are message bytes remaining in the tag, the interrogator waits a while and then repeats *Authenticate* for step 2 until the response from the tag indicates that the message is complete and that no more data is available from the tag. Now the interrogator begins with message processing.

2.6 Tag Life Cycle and Key Management

We will now briefly discuss aspects of the tag's life cycle, the key management, and the roles involved. In figure 6 we can see the *System Integrator* and the *Tag Issuer* shown as different roles. In this scenario the *System Integrator* owns the asymmetric key pair K_E, K_D (the RAMON encryption and decryption keys), marked with blue and red colour, respectively (in b/w print these keys show up as grey and dark grey). The *System Integrator* hands over the public key K_E to the *Tag Issuer*.

Now the *Tag Issuer* produces a couple of tags with uniquely generated tag IDs and signs them with its private signature key K_S . The signature key pair is marked with light yellow colour (or light grey). Note that the generation of tag ID signatures is optional. In each tag the *Tag Issuer* stores the (signed) tag ID and the Ramon encryption key K_E . No secret key needs to be stored in the tag.

In addition the *Tag Issuer* gives the signature verification key K_V and a list of (signed) tag IDs to the *System Integrator*. Now the *System Integrator* can verify the authenticity of this ID list.

The *System Integrator* sets up *Interrogator* sites with a secure store containing the tag IDs and the private RAMON decryption key K_D . Thus the *Interrogator* can decrypt the RAMON messages, identify the tag and eventually authenticate it if the signature matches.

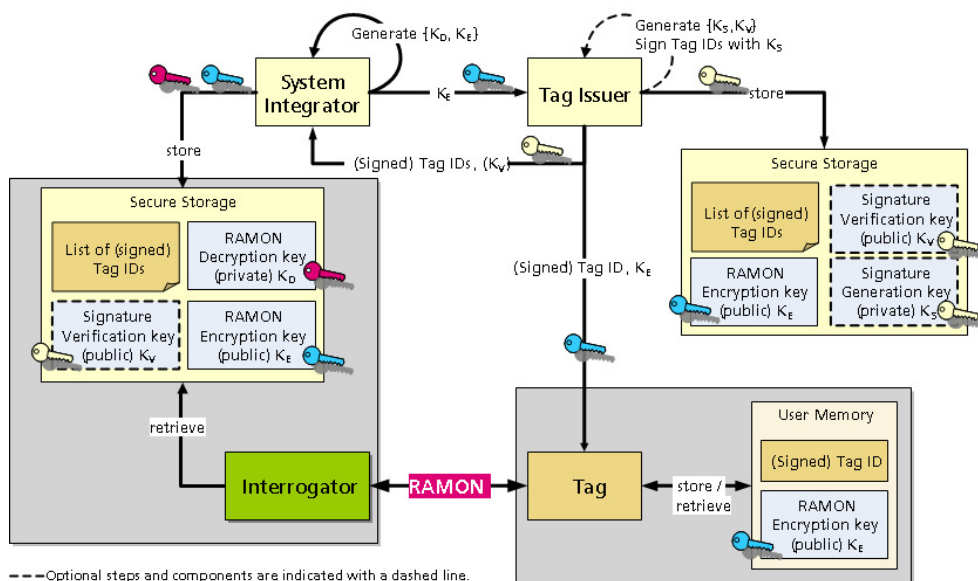

Figure 6: Tag Life Cycle and Key Management

3 PRELIMINARY PROTOTYPE

The authentication protocol specified so far requires modified tags which support the secure authentication procedure, but it also requires UHF interrogators which implement the *Authenticate* command that is still in the standardisation process. However, such an interrogator is currently not available.

For that reason it is necessary to emulate the behaviour of the secure UHF tag on hardware which is compatible with the current ISO/IEC 18000-6 Type C standard and use commands which are available in this standard.

In order to achieve maximum flexibility in the implementation of cryptographic functions we decided to extend a standard state machine controlled UHF tag with a microprocessor. Both units are closely coupled with shared volatile memory which permits the microcontroller to receive messages via the UHF channel and to return responses.

3.1 Hardware Description

In order to provide a smooth migration path we started with an already existing standard UHF tag. This device, when mounted on a PCB, can communicate its digital data stream to an external device and can backscatter the data received from that device. Thus the function of the former UHF tag is reduced to an analogue front end (AFE).

The switch from autonomous mode of the tag to AFE mode is made by means of a command sequence sent to the tag's state machine from the at-

tached device via an I²C bus specially provided for that purpose.

The attached device is represented by a Spartan 6 FPGA which is located on a suitable evaluation board where the connections to the external world are provided. The whole setup is shown in figure 7.

Within the FPGA the state machine for an ISO/IEC 18000-6 Type C compliant tag is replicated, but with some modifications which facilitate the implementation of the secure functions presented in this paper

In the FPGA prototype all memory is provided as non-persistent RAM.

3.2 Add-ons for Security Functions

The additional processing elements represented in the FPGA comprise a Texas Instruments MSP430X compatible CPU together with a couple of peripherals which are also compatible with the original peripherals to some extent. The most important one of these peripherals for our purpose is a hardware multiplier capable of calculating a 32 bit result of a 16×16 bit integer multiplication within one clock cycle. By using the multiply-add mode of this multiplication unit it is possible to implement the long integer arithmetic functions required for Public Key cryptography in a very efficient way.

Another valuable peripheral for strong cryptography is an AES coprocessor capable of supporting all the three standardised key sizes, i.e. 128, 129, and 256 bits.

Other peripherals comprise a timer and a couple

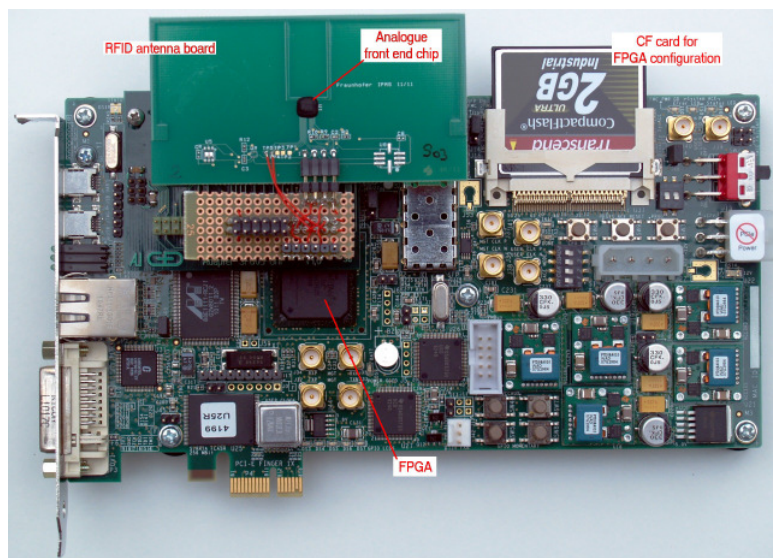

Figure 7: FPGA board and analogue front end.

of free programmable port bits. One of these bits is used to generate serial output which can be displayed in a terminal window on the controlling PC.

The microprocessor itself is controlled through a special USB-to-PC interface from a debugger running on the PC.

The MSP430X currently runs at a clock rate of 1,25 MHz which is significantly below the maximum speed for this processor architecture. The speed was chosen to achieve command execution performance close to that when a final tag design has to operate in a power-limited environment.

3.3 Tag-CPU Communication

The tag (i.e. the part within the FPGA which is based on the ISO/IEC 18000-6 Type C state machine) and the CPU are loosely coupled by means of a common memory buffer of 128 16-bit words which is within the address space of the tag's state machine. Specifically, it is located within the TID (tag ID) memory bank.

The CPU can access (read and write) all the tag memory by means of a special peripheral memory access controller which also solves the task of arbitration in case of conflicting access attempts. The access rules are simple:

- After the CPU posted a request for a specific address, it has to wait for an interrupt which signals the access grant.
- If the tag tries to access the memory while the CPU has access, it is delayed until the CPU is done. This may sometimes lead to a timeout on the tag's air interface.
- In all other cases the tag state machine and the CPU may run independently.

Whenever the tag writes to a specific address into the TID bank, a specific interrupt is generated for the CPU to signal that a command message was received over the air interface. This mechanism facilitates the CPU to stay in a power-save sleep state most of the time until it has to respond to an external request.

3.4 Over the Air Data Transfer

As we saw above any data from outside the CPU has to be passed across the communication buffer in the TID bank. The ISO/IEC 18000-6 Type C standard defines (sometimes optional) commands to serve this purpose.

- For reading data from the communication buffer the *Read* and *BlockRead* commands are available. The first reads a single 16 bit

word from a specific address while the latter transfers a specified number of such words from adjacent locations.

- For writing data from outside into the communication buffer the commands *Write* and *BlockWrite* are provided in the standard.

There is an issue with *BlockWrite* though: as any ISO/IEC 18000-6 Type C command has to be completed within 20 ms, this may be too short for writing to an extended number of E²PROM cells within a single command. As standard tags normally use this memory type, they often do not support *BlockWrite*, or only with a length of just a single word. This situation is completely different for a RAM buffer.

Our prototype is currently confined to use *BlockRead* for reading from the tag and repeated *Write* for writing to the tag.

3.5 The Transport Protocol

In the proposed preliminary setup any messages between the interrogator and the tag's CPU have to be passed through the shared memory. In order to facilitate this transfer the transport protocol T=1 which is widely used in the smart card environment was chosen.

Although this protocol introduces some overhead, it provides a couple of useful features, like consistency checking with repetition of messages if necessary, buffer size negotiation, chaining of long messages, and others.

3.6 The Application Protocol

The application protocol layer is also taken from the smart card domain as specified in ISO/IEC 7816. In this standard an application protocol data unit (APDU) comprises a class byte, an instruction byte, two parameter bytes, an optional length specification followed by the indicated number of data bytes, and eventually an optional specification of the expected response size. This makes up a command message.

Response messages comprise the response data, if any, followed by a two-byte status word.

In the ISO/IEC 7816 paradigm the smart card or secure token or, in our case, the secure UHF tag always takes the role of a server while the interrogator, or rather the device which controls the interrogator, takes the role of a client. Thus, during a message sequence, the secure UHF tag receives a command APDU, processes the command, and eventually returns a response APDU.

3.7 Secure Messaging

Within the authentication method as proposed for WD 29167-1 in a previous section, the confidential and authentic exchange of arbitrary data is not envisaged.

However, in some applications it is desirable to communicate in a secure manner which is known as secure messaging. Basically there are two stages of secure messaging which can be applied separately or combined.

- **Message Authentication:** this ensures the integrity of a message, No one other than the originator can generate or alter such a message after a message authentication code (“MAC”) is attached to the message, nor can the originator deny his authorship. The MAC is calculated over that part of the message which is to be secured.
- **Message Encryption;** this ensures the confidentiality of a message. Only the originator and the receiver of the message can see its clear content.

As mentioned, both security mechanisms can be combined. In that case the state of the art requires applying the encryption first and message authentication afterwards.

For both security mechanisms a number of cryptographic algorithms are available. In our prototype we used AES-CBC-128 for the encryption and AES-CMAC- 128 for message authentication. This choice was based on the availability of coprocessor support for the AES crypto-primitive.

4 RESULTS

With the FPGA setup we were able to execute a secure authentication test suite comprising a Rabin-Montgomery authentication of the tag, followed by an AES based mutual authentication, writing a data record with secure messaging (encrypted and authenticated), and then securely reading back the data just written.

With the microprocessor running at a clock rate of 1.25 MHz we obtained satisfactory results. Thanks to the integrated multiplication unit the Rabin-Montgomery authentication with a modulus of 1024 bit size was performed within 134 ms. This does not include the time required to transmit the result to the interrogator which takes more than 330 ms. The buffer determines if the components involved require the authentication message to be split into at least two fragments, which adds to the communication times. However, we do not expect to

have buffers big enough to transfer the whole message within a single block.

The performance of the secure messaging tests was less satisfactory. This was due to the fact that a **BlockWrite** command with sufficient data length was neither supported by our AFE nor by the UHF reader firmware. Therefore, we had to fall back to an appropriate number of **Write** commands which imposed a considerable time overhead. Thanks to the AES coprocessor, the AES-based encryptions were calculated with considerable performance as expected,. However, overall execution times were dominated by the communication.

5 CONCLUSIONS

As we expect the standardisation to take some time we will continue to experiment with setups based on the shared memory approach taken with the FPGA. For further evaluations and estimations on power consumption and operating range the FPGA should be replaced with an ASIC implementing basically the same functionality.

After the completion of ISO/IEC WD 29167 as a standard and the availability of compatible readers we will continue to implement this technology in order to enhance the performance of secure UHF tags.

REFERENCES

- Finkenzeller, Klaus,** 2012: *RFID Handbuch (RFID Handbook)*, Hanser Verlag, Munich, 6th edition, ISBN 978-3446429925, <http://rfid-handbook.de>
- ISO/IEC 18000-6,** 2010: Information technology - Radio frequency identification for item management - Part 6: Parameters for air interface communications at 860 MHz to 960 MHz, *International Organization for Standardization, Geneva, Switzerland*
- ISO/IEC FDIS 18000-63,** 2012: Information technology - Radio frequency identification for item management - Part 63: Parameters for air interface communications at 860 MHz to 960 MHz Type C, *International Organization for Standardization, Geneva, Switzerland.*
- Mendezes, Alfred J., van Oorschot, Paul C., Vanstone, Scott A.,** 1997: *Handbook of Applied Cryptography*, CRC Press, Inc., New York, ISBN 0-8493-8523-7.
- Montgomery, Peter L:** 1985. Modular Multiplication without Trial Division. In *Math. Computation, Vol. 44*, 1985, p. 519–521.
- Rabin, Michael O.,** 1979: Digitalized Signatures and Public-Key Functions as Intractable as Factorization. In *MIT-LCS-TR 212, MIT Laboratory for Computer Science*, January 1979.